

JVC



ENGLISH

DEUTSCH

FRANÇAIS

NEDERLANDS

CASSETTE RECEIVER
CASSETTEN-RECEIVER
RADIOCASSETTE
RADIO/CASSETTESPELER

KS-FX463R/KS-FX460R

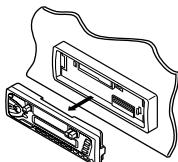

KS-FX463R

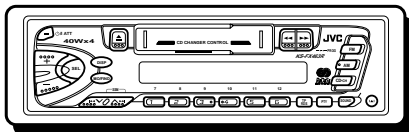

KS-FX460R

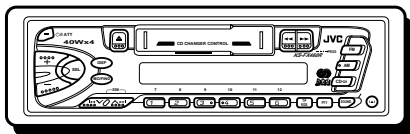

For installation and connections, refer to the separate manual.
Angaben zu Einbau und Verkabelung entnehmen Sie bitte der gesonderten Anleitung.
Pour l'installation et les raccordements, se référer au manuel séparé.
Zie de afzonderlijke handleiding voor details aangaande het installeren en verbinden van het toestel.

INSTRUCTIONS

BEDIENUNGSANLEITUNG
MANUEL D'INSTRUCTIONS
GEBRUIKSAANWIJZING

Thank you for purchasing a JVC product. Please read all instructions carefully before operation, to ensure your complete understanding and to obtain the best possible performance from the unit.

CONTENTS



BASIC OPERATIONS 3

RADIO BASIC OPERATIONS 4

Listening to the radio 4
 Storing stations in memory 5
 Tuning into a preset station 7



RDS OPERATIONS 8

What you can do with RDS EON 8
 Other convenient RDS functions and adjustments 14



TAPE OPERATIONS 16

Listening to a tape 16



SOUND ADJUSTMENTS 17

Selecting preset sound modes 17
 Adjusting the sound 18
 Storing your own sound adjustments 19



OTHER MAIN FUNCTIONS 20

Setting the clock 20
 Changing the general settings 22
 Detaching the control panel 25



CD CHANGER OPERATIONS 26

Playing CDs 26
 Selecting CD playback modes 28



MAINTENANCE 29

To extend the lifetime of the unit 29



TROUBLESHOOTING 30

SPECIFICATIONS 31

Note:
 For security reasons, a numbered ID card is provided with this unit, and the same ID number is imprinted on the unit's chassis. Keep the card in a safe place, as it will help the authorities to identify your unit if stolen.

BEFORE USE

- * **For safety....**
- Do not raise the volume level too much, as this will block outside sounds, making driving dangerous.
- Stop the car before performing any complicated operations.

- * **Temperature inside the car....**
- If you have parked the car for a long time in hot or cold weather, wait until the temperature in the car becomes normal before operating the unit.

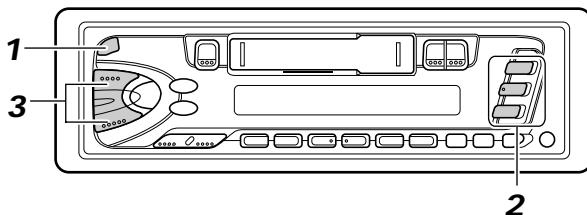

Note:

When you use this unit for the first time, set the built-in clock correctly, see page 20.



Turn on the power.

Note on One-Touch Operation:

- When you select tuner as a source in step 2 below, the power automatically comes on. You do not have to press this button to turn on the power.
- If the cassette is already in the cassette compartment, tape play starts automatically. However, it is not recommended to leave the cassette in the compartment when turning off the power or ignition key. It may damage the tape head and the cassette.

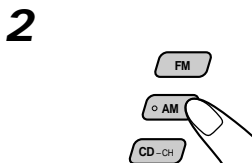

Play the source.

To operate the tuner, see pages 4 – 15.
To operate the tape deck, see page 16.
To operate the CD changer, see pages 26 – 28.

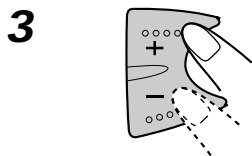

Adjust the volume.

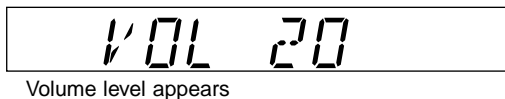

4 Adjust the sound as you want (see pages 17 – 19).

To drop the volume in a moment

Press \odot /I/ATT briefly while listening to any source. “ATT” starts flashing on the display, and the volume level will drop in a moment.

To resume the previous volume level, press the button briefly again.

To turn off the power

Press \odot /I/ATT for more than 1 second.



Listening to the radio

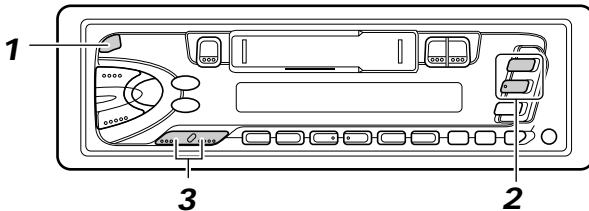

1



Turn on the power.

Note on One-Touch Operation:

When you select a band in step 2 below, the power automatically comes on. You do not have to press this button to turn on the power.

2

Select the band (FM1, FM2, FM3 or AM).

You can select any one of FM1, FM2, and FM3 to listen to an FM station.

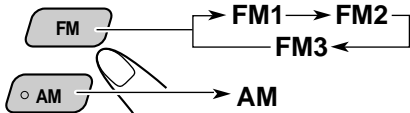

Note:

When a cassette is in the cassette compartment, you cannot select the tuner. Be sure to eject the cassette from the cassette compartment to listen to the radio.

3

Start searching a station.

When a station is received, searching stops.

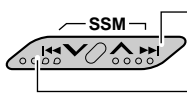

To search stations of higher frequencies.

To search stations of lower frequencies.

To stop searching before a station is received, press the same button you have pressed for searching.

To tune in a particular frequency manually:

1 Select the band (FM or AM).

Press FM or AM.

2 Press and hold or until "M" starts flashing on the display.

Now you can manually change the frequency while "M" is flashing.

3 Press or repeatedly until the frequency you want is reached.

- If you hold down the button, the frequency keeps changing (in 50 kHz intervals for FM and 9 kHz intervals for AM — MW/LW) until you release the button.

Storing stations in memory

You can use one of the following two methods to store broadcasting stations in memory.

- Automatic preset of FM stations: SSM (Strong-station Sequential Memory)
- Manual preset of both FM and AM stations

FM station automatic preset: SSM

You can preset 6 local FM stations in each FM band (FM1, FM2, and FM3).

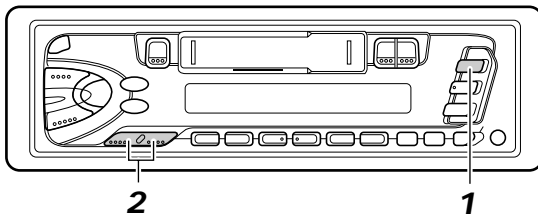
1

Select the FM band number (FM1, FM2 or FM3) you want to store FM stations into.

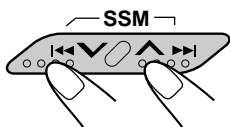
2

Press and hold both buttons for more than 2 seconds.

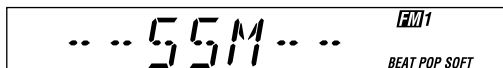

“SSM” appears, then disappears when automatic preset is over.

Local FM stations with the strongest signals are searched and stored automatically in the band number you have selected (FM1, FM2 or FM3). These stations are preset in the number buttons — No. 1 (lowest frequency) to No. 6 (highest frequency).

When automatic preset is over, the station stored in number button 1 will be automatically tuned in.



Manual preset

You can preset up to 6 stations in each band (FM1, FM2, FM3 and AM) manually.

EXAMPLE: Storing an FM station of 88.3 MHz into preset number 1 of the FM1 band

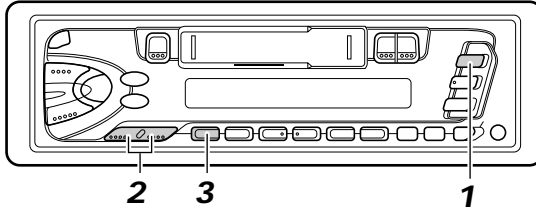

1

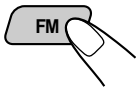

Select the FM1 band.



2

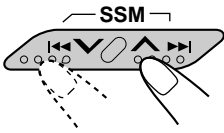

Tune into a station of 88.3 MHz.

See page 4 to tune into a station.

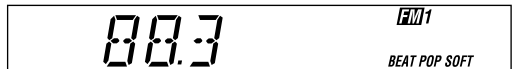

3

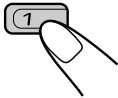

Press and hold the button for more than 2 seconds.



"P1" flashes for a few seconds.

4 Repeat the above procedure to store other stations into other preset numbers.

Notes:

- A previously preset station is erased when a new station is stored in the same preset number.
- Preset stations are erased when the power supply to the memory circuit is interrupted (for example, during battery replacement). If this occurs, preset the stations again.

Tuning into a preset station

You can easily tune into a preset station.

Remember that you must store stations first. If you have not stored them yet, see pages 5 and 6.

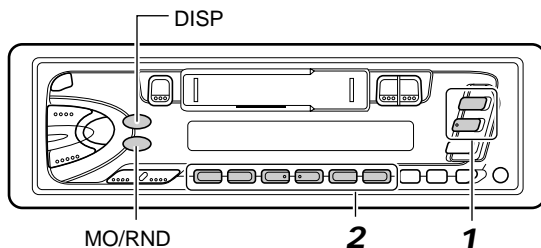
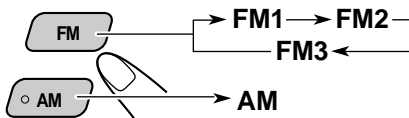
1

Select the band (FM1, FM2, FM3 or AM) you want.

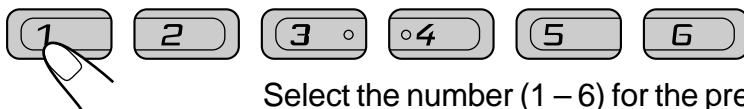
2

Select the number (1 – 6) for the preset station you want.

To change the display information while receiving an FM RDS station

Press DISP. Each time you press the button, the display changes as follows:

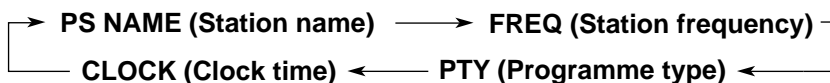

When an FM stereo broadcast is hard to receive:

Press MO/RND (mono/random) while listening to an FM stereo broadcast. The MO (mono) indicator lights up on the display. The sound you hear becomes monaural but reception will be improved.

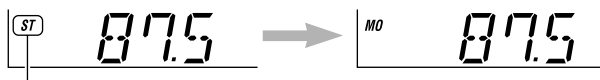

Lights up when receiving an FM broadcast in stereo.

To restore the stereo effect, press the button again.



What you can do with RDS EON

RDS (Radio Data System) allows FM stations to send an additional signal along with their regular programme signals. For example, the station send their station names, as well as information about what type of programme they broadcast, such as sports or music, etc. Another advantage of RDS function is called "EON (Enhanced Other Networks)." The EON indicator lights up while receiving an FM station with the EON data. By using the EON data sent from a station, you can tune into a different station of a different network broadcasting your favorite programme or traffic announcement while listening to another programme or to another source such as tape.

- By receiving the RDS data, this unit can do the following:
- Tracing the same programme automatically (Network-Tracking Reception)
 - Standby Reception of TA (Traffic Announcement) or your favorite programme
 - PTY (Programme Type) search
 - TP (Traffic Programme) search
 - And some other functions

Tracing the same programme automatically (Network-Tracking Reception)

When driving in an area where FM reception is not good, the tuner built in this unit automatically tune in another RDS station, broadcasting the same programme with stronger signals. So, you can continue to listen to the same programme in its finest reception, no matter where you drive. (See the illustration on the next page.)

Two types of the RDS data are used to make Network-Tracking Reception work correctly — PI (Programme Identification) and AF (Alternative Frequency).

Without receiving these data correctly from the RDS station you are listening to, Network-Tracking Reception will not operate.



To use Network-Tracking Reception, press and hold TP/RDS (Traffic Programme/Radio Data System) for more than 1 second. Each time you press and hold the button, Network-Tracking Reception modes change as follows:





Mode 1

The AF indicator lights up but the REG indicator does not.
Network-Tracking is activated with Regionalization set to “off.”
Switches to another station within the same network when the receiving signals from the current station become weak.

Note:

In this mode, the programme may differ from the one currently received.

Mode 2

Both the AF indicator and the REG indicator light up.
Network-Tracking is activated with Regionalization set to “on.”
Switches to another station, within the same network, broadcasting the same programme when the receiving signals from the current station become weak.

Mode 3

Neither the AF indicator nor the REG indicator lights up.
Network-Tracking is deactivated.

The same programme can be received on different frequencies.

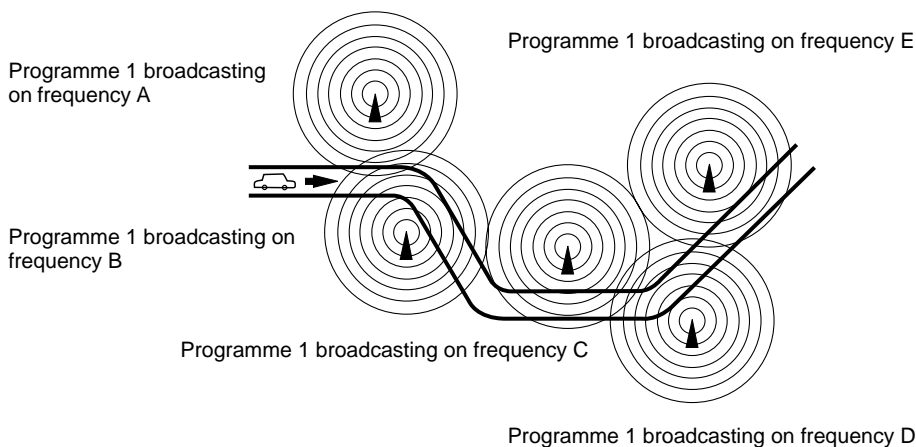



Using Standby Reception

Standby Reception allows the unit to switch temporarily to your favorite programme (PTY: Programme Type) and Traffic Announcement (TA) from the current source — another FM station and Tape or CD changer.

Note:

Standby Reception will not work if you are listening to an AM station.

TA Standby Reception

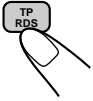

- When you press TP/RDS while listening to an FM station, the TP indicator is lit during reception of a TP (Traffic Programme) station and the TA standby mode is engaged.

Note:

When the station being received is not a TP station, the TP indicator flashes. Press $\blacktriangle\blacktriangleright\blacktriangleright$ or $\blacktriangleleft\blacktriangleleft$ to engage the TA standby mode. "SEARCH" appears on the display, and TP station search starts. When a TP station is tuned in, the TP indicator is lit.

- If you are listening to a tape or CD changer, and wish to listen to a TP station, press TP/RDS or TP to enter the TA standby mode. (The TP indicator lights up.)

If a traffic programme starts broadcasting while the TA standby mode is active, "TRAFFIC" appears and the playback source changes to the FM band. The volume increases to the preset TA volume level and the traffic programme can be heard (see page 14).

To deactivate the TA standby mode, press TP/RDS again.

PTY Standby Reception



- When you press PTY while listening to an FM station, the PTY indicator is lit during reception of a PTY station and the PTY standby mode is engaged. The selected PTY name stored on page 12 flashes for 5 seconds.

Note:

When the station being received is not a PTY station, the PTY indicator flashes. Press $\blacktriangle\blacktriangleright\blacktriangleright$ or $\blacktriangleleft\blacktriangleleft$ to engage the PTY standby mode. "SEARCH" appears on the display, and PTY station search starts. When a PTY station is tuned in, the PTY indicator is lit.

- If you are listening to a tape or CD changer, and wish to listen to a selected PTY broadcast, press PTY to enter the PTY standby mode. (The PTY indicator lights up.)

If the selected PTY programme starts broadcasting while the PTY standby mode is active, the selected PTY name appears and the playback source changes to the FM band. The selected PTY programme can then be heard.

To deactivate the PTY standby mode, press PTY again.



Selecting Your Favorite Programme for PTY Standby Reception

You can select your favorite programme for PTY Standby Reception to store in memory. When shipped from the factory, "NEWS" is stored as the programme type for PTY Standby Reception.

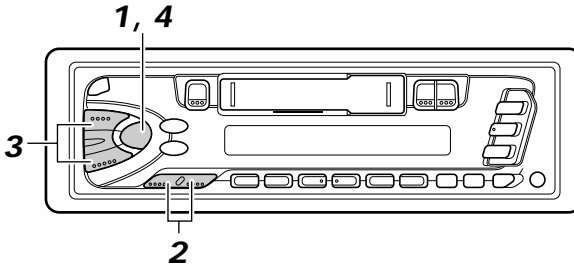

1



Press and hold SEL (select) for more than 2 seconds to enter the general setting mode (see page 22).

2

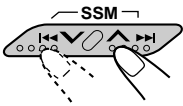

Select "PTY STBY (standby)" if not shown on the display.

3

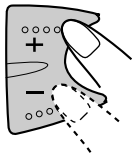

Select one of twenty-nine PTY codes. (See page 15.)

Selected code name appears on the display and is stored into memory.

4



Finish setting.

Searching Your Favorite Programme

You can search one of your 6 favorite programme types stored in memory. When shipped from the factory, the following 6 programme types have been stored in the number buttons (1 to 6).

To change the factory preset settings, see page 12.

To search your favorite programme, see page 13.

1	2	3	4	5	6
POP M	ROCK M	EASY M	CLASSICS	AFFAIRS	VARIED



To store your favorite programme types

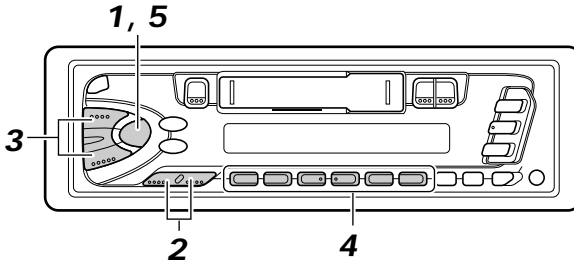

1



Press and hold SEL (select) for more than 2 seconds to enter the general setting mode (see page 22).

2



Select "PTY SRCH (search)" if not shown on the display.

3



Select one of twenty-nine PTY codes. (See page 15.)

Selected code name appears on the display.

- If the code already stored in memory is selected, it will flash on the display.

4

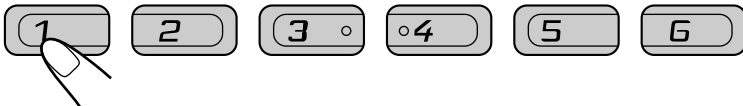

Press and hold the number button for more than 2 seconds to store the PTY code selected into the preset number you want.

The selected code name will flash on the display.

5



Finish setting.

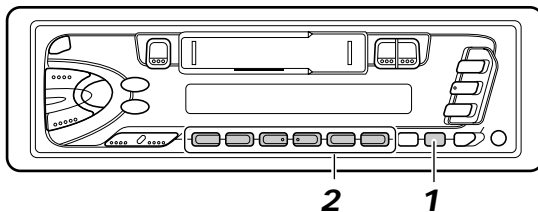

To search your favorite programme type

**1**

Press and hold PTY (programme type) for more than 1 second while listening to an FM station.

The last selected PTY code appears.

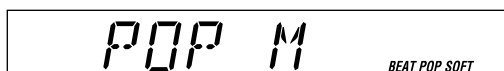
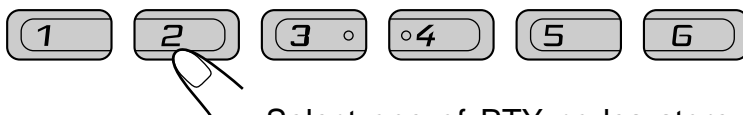
**2**

Select one of PTY codes stored in preset number buttons (1 to 6).

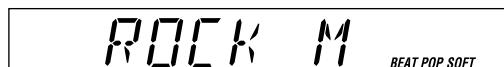

Ex. When "ROCK M" is stored in preset number button 2.

PTY search for your favorite programme starts after 5 seconds.

- If there is a station broadcasting a programme of the same PTY code you selected, that station is tuned in.
- If there is no station broadcasting a programme of the same PTY code you selected, the station will not change.

Note:

In some areas, the PTY search will not work correctly.



Other convenient RDS functions and adjustments

Changing the display mode while listening to an FM station

You can change the initial indication on the display to station name (PS NAME), station frequency (FREQ), or clock time (CLOCK) while listening to an FM RDS station.

- See also “Changing the general settings” on page 22.

1. Press and hold SEL (select) for more than 2 seconds to call up the general setting mode.
2. Press **▲▶▶** or **◀◀▼** to select “DISPMODE (display mode).”
3. Press + or – to set to the desired indication — PS NAME (station name), FREQ (station frequency), or CLOCK (clock time).

Note:

By pressing DISP, you can also change the display while listening to an FM RDS station. Each time you press the button, the following information appears on the display:

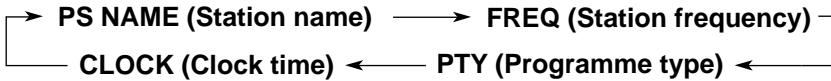

** Then, the display goes back to the original indication in several seconds.*

Setting the TA volume level

You can preset the volume level for TA Standby Reception. When a traffic programme is received, the volume level automatically changes to the preset level.

- See also “Changing the general settings” on page 22.

1. Press and hold SEL (select) for more than 2 seconds to call up the general setting mode.
2. Press **▲▶▶** or **◀◀▼** to select “TA VOL (volume).”
3. Press + or – to the desired volume.



Automatic clock adjustment

When shipped from the factory, the clock built in this unit is set to be readjust automatically using the CT (Clock Time) data in the RDS signal.

If you do not want to use automatic clock adjustment, follow the procedure below.

- See also “Changing the general settings” on page 22.

1. Press and hold SEL (select) for more than 2 seconds to call up the general setting mode.
2. Press $\blacktriangle\blacktriangleright\blacktriangleright$ or $\blacktriangleleft\blacktriangleleft\blacktriangledown$ to select “AUTO ADJ (adjust).”
3. Press – to select “ADJ OFF.”
Now automatic clock adjustment is canceled.

To reactivate clock adjustment, repeat the same procedure and select “ADJ ON” in step 3 by pressing the + button.

Note:

It takes about 2 minutes to adjust the time using the CT data. So, you must tune to the station for more than 2 minutes continuously; otherwise, the clock time will not be adjusted.

PTY codes

NEWS:	News	SOCIAL:	Programmes on social activities
AFFAIRS:	Topical programmes expanding on current news or affairs	RELIGION:	Programmes dealing with any aspect of belief or faith, or the nature of existence or ethics
INFO:	Programmes which impart advice on a wide variety of topics	PHONE IN:	Programmes where people can express their views either by phone or in a public forum
SPORT:	Sport events	TRAVEL:	Programmes about travel destinations, package tours, and travel ideas and opportunities
EDUCATE:	Educational programmes	LEISURE:	Programmes concerned with recreational activities such as gardening, cooking, fishing, etc.
DRAMA:	Radio plays	JAZZ:	Jazz music
CULTURE:	Programmes on national or regional culture	COUNTRY:	Country music
SCIENCE:	Programmes on natural science and technology	NATION M:	Current popular music from another nation or region, in that country's language
VARIED:	Other programmes like comedies or ceremonies	OLDIES:	Classic pop music
POP M:	Pop music	FOLK M:	Folk music
ROCK M:	Rock music	DOCUMENT:	Programmes dealing with factual matters, presented in an investigative style
EASY M:	Easy-listening music		
LIGHT M:	Light music		
CLASSICS:	Classical music		
OTHER M:	Other music		
WEATHER:	Weather information		
FINANCE:	Reports on commerce, trading, the Stock Market, etc.		
CHILDREN:	Entertainment programmes for children		



TAPE OPERATIONS

ENGLISH

Listening to a tape

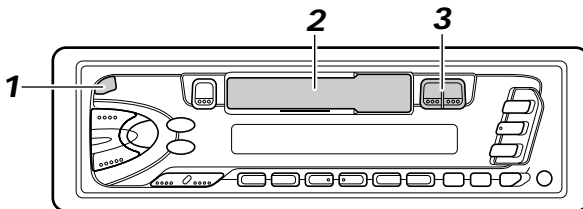

1



Turn on the power.

2

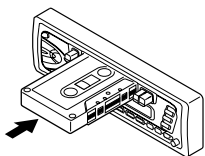

Insert a cassette.

When one side of the tape reaches its end during play, the other side of the tape automatically starts playing. (Auto Reverse)

3

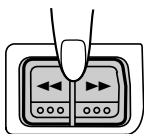

Select the tape direction.

• Press both buttons at the same time.
Each time you press both buttons, the tape direction changes alternatively – forward (TAPE >>>) and reverse (TAPE <<<).

To stop play and eject the cassette

Press ▲.

Tape play stops and the cassette ejects from the cassette compartment.

You can hear the last received station or CD playback from the CD changer.

• You can also eject the cassette with the unit turned off.

To fast-wind a tape

Press either ►► or ◀◀.

The tape will be wound in the direction of the arrows (►► or ◀◀).

To restart playback, press ►► or ◀◀ lightly.

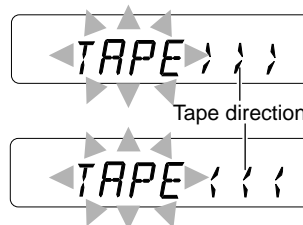



Selecting preset sound modes

You can select a preset sound adjustment suitable to the music genre.

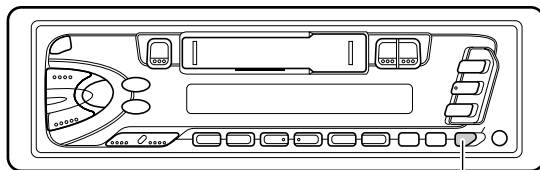

SOUND

Each time you press SOUND, the sound mode changes as follows.



Indication	For:	Preset values		
		Bass	Treble	Loudness
SCM OFF	(Flat sound)	00	00	On
BEAT	Rock or disco music	+2	00	On
POP	Light music	+4	+1	Off
SOFT	Quiet background music	+1	-3	Off

Notes:

- You can adjust the preset sound mode to your preference, and store it in memory. If you want to adjust and store your original sound mode, see “Storing your own sound adjustments” on page 19.
- To adjust only the bass and treble reinforcement levels to your preference, see “Adjusting the sound” on page 18.
- When one of the sound modes is selected, it is shown on the display as follows:



For example, when “POP” is selected.



Adjusting the sound

You can adjust the sound characteristics to your preference.

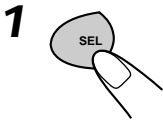
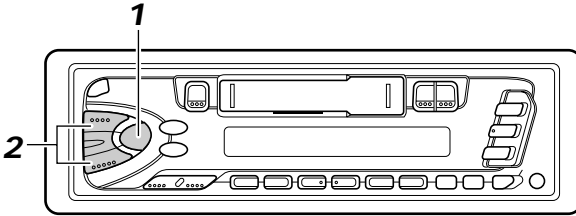

Select the item you want to adjust.

→ **BAS** → **TRE** → **FAD** → **BAL** → **LOUD** → **VOL**

Indication	To do:	Range
BAS (Bass)	Adjust the bass	-6 (min.) — +6 (max.)
TRE (Treble)	Adjust the treble	-6 (min.) — +6 (max.)
FAD (Fader)*	Adjust the front and rear speaker balance	R6 (rear only) — F6 (front only)
BAL (Balance)	Adjust the left and right speaker balance	L6 (left only) — R6 (right only)
LOUD (Loudness)	Boost low and high frequencies to produce a well-balanced sound at low volume level.	ON — OFF
VOL (Volume)	Adjust the volume	00 (min.) — 50 (max.)

Note:

* If you are using a two-speaker system, set the fader level to "00."

2

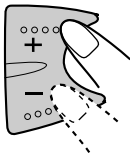

Adjust the level.

Press the + button to turn on the loudness function, and the - button to turn it off.

Note:

Normally the + and - buttons work as the volume control buttons. So you do not have to select "VOL" to adjust the volume level.



Storing your own sound adjustments

You can adjust the sound modes (BEAT, POP, SOFT: see page 17) to your preference and store your own adjustments in memory.

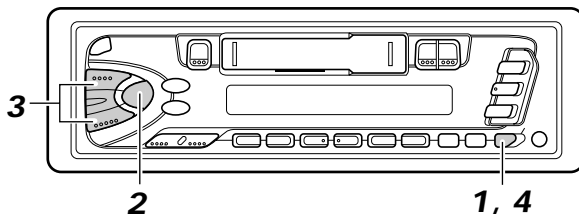

- 

1 Call up the sound mode you want to adjust.
See page 17 for details.

Within 5 seconds
- 

2 Select “BAS”, “TRE” or “LOUD.”

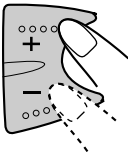
Within 5 seconds
- 

3 Adjust the bass or treble level or turn the loudness function ON/OFF.
See page 18 for details.

Within 5 seconds
- 

4 Press and hold SOUND until the sound mode you have selected in step 1 flashes on the display.
Your setting is stored in memory.
- 5** Repeat the same procedure to store other settings.

To reset to the factory settings

Repeat the same procedure and reassign the preset values listed in the table on page 17.

Setting the clock

You can also set the clock system either to 24 hours or 12 hours.

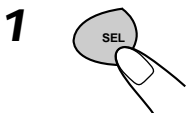
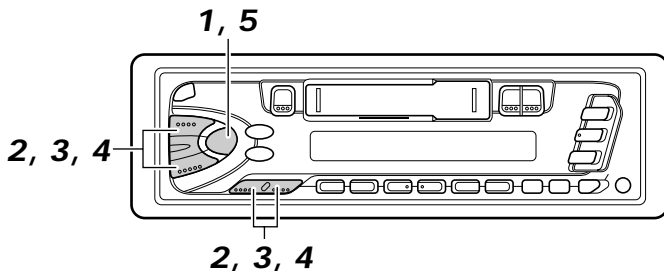

Press and hold SEL (select) for more than 2 seconds to enter the general setting mode.

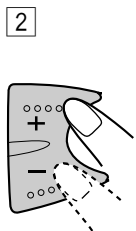
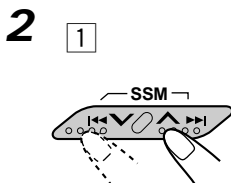

Set the hour.

- 1** Select "CLOCK H (Hour)" if not shown on the display.
- 2** Adjust the hour.

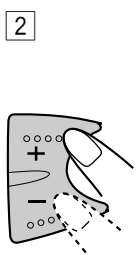
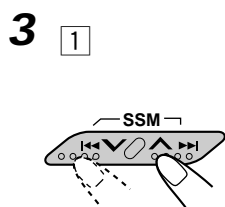

Set the minute.

- 1** Select "CLOCK M (Minute)."
- 2** Adjust the minute.

4 1

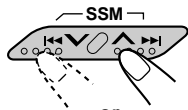

2



Set the clock system.

- 1 Select "24H/12H."
- 2 Select "24H" or "12H."

5



Start the clock.

To check the current clock time (changing the display mode)

Press DISP repeatedly. Each time you press the button, the display mode changes as follows.

During tuner operation:	During tape operation:	During CD changer operation:
<ul style="list-style-type: none"> • For FM RDS stations See page 14. • For AM and other FM stations Frequency ↔ Clock 	<p>Play mode ↔ Clock</p>	<p>Clock → Elapsed playing time → Disc number</p>

Changing the general settings

You can change the items listed on the next page to your preference.

Basic Procedure

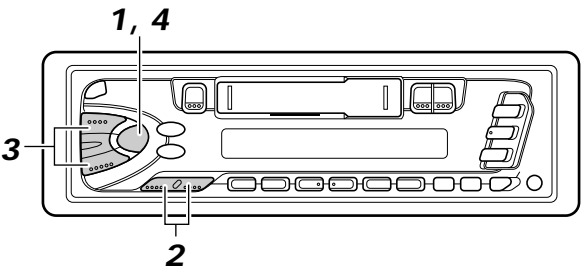

1  Press and hold SEL (select) for more than 2 seconds to enter the general setting mode.

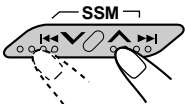
2  Select the item you want to adjust. (See page 23.)

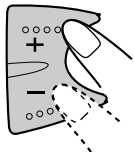
3  Select or adjust the item selected above.

4  Finish setting.

		1		2		3		4	
		Select.		Set.		Finish the setting		Factory-preset settings	See page
CLOCK H	Hour adjustment	Back	Advance	0:00	20				
CLOCK M	Minute adjustment	Back	Advance						
24H/12H	24/12-hour time display	12H	24H	24H	20				
AUTO ADJ	Automatic setting of the clock	ADJ OFF	ADJ ON	ADJ ON	15				
DISPMODE	Display mode	PS NAME ↔ FREQ ↕ CLOCK ↕		PS NAME	14				
CH DISP	Changer display	TIME	DISC	DISC	24				
PTY STBY	PTY standby	29 programme types (See page 15.)		NEWS	11				
PTY SRCH	PTY search			(See page 11.)	12				
TA VOL	Traffic announcement volume	VOL (00-50)		VOL (20)	14				
TEL	Audio mute for cellular phone system	OFF ↔ MUTING 1 ↕ MUTING 2 ↕		OFF	24				

Selecting the initial CD information display

You can select what type of the CD playback information to be initially shown on the display when you start playing a CD. When shipped from the factory, the disc number and track number information is selected to be shown.

- **DISC:** Disc number and track number appear on the display.
- **TIME:** Elapsed playing time appears on the display.

1. Press and hold SEL (select) for more than 2 seconds to call up the general setting mode.
2. Press **▲▶▶** or **◀◀▼** to select "CH DISP (changer display)."
3. Press + or – to select the desired mode.

The initial CD information display changes as follows:

TIME ↔ DISC

To see the other information while playing a CD, press DISP.

Each time you press the button, the information changes alternately.

Selecting the telephone muting

This mode is used when a cellular phone system is connected. Depending on the phone system used, select either "MUTING 1" or "MUTING 2," whichever mutes the sounds from this unit. When shipped from the factory, this mode is deactivated.

- **MUTING 1:** Select this if this setting can mute the sounds.
- **MUTING 2:** Select this if this setting can mute the sounds.
- **OFF:** Cancels the telephone muting.

1. Press and hold SEL (select) for more than 2 seconds to call up the general setting mode.
2. Press **▲▶▶** or **◀◀▼** to select "TEL (telephone)".
3. Press + or – to select the desired mode.

The telephone muting mode changes as follows:

→ MUTING 1 ↔ MUTING 2 ↔ OFF ←

Detaching the control panel

You can detach the control panel when leaving the car.
When detaching or attaching the control panel, be careful not to damage the connectors on the back of the control panel and on the panel holder.

How to detach the control panel

Before detaching the control panel, be sure to turn off the power.

- 1 Unlock the control panel.

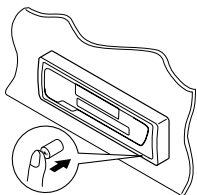

- 2 Lift and pull the control panel out of the unit.

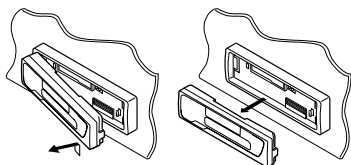

- 3 Put the detached control panel into the provided case.

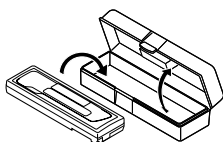

How to attach the control panel

- 1 Insert the left side of the control panel into the groove on the panel holder.

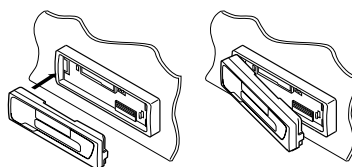

- 2 Press the right side of the control panel to fix it to the panel holder.

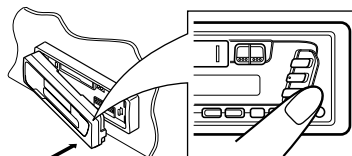

Note on cleaning the connectors:

If you frequently detach the control panel, the connectors will deteriorate. To minimize this possibility, periodically wipe the connectors with a cotton swab or cloth moistened with alcohol, being careful not to damage the connectors.

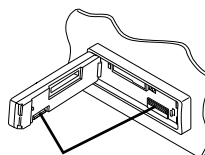

Connectors



CD CHANGER OPERATIONS

ENGLISH

When used with a JVC CD automatic changer (separately purchased).

We recommend that you use one of the CH-X series with your unit.

If you have another CD automatic changer, consult your JVC IN-CAR ENTERTAINMENT dealer for connections.

- For example, if your CD automatic changer is one of the KD-MK series, you need a cord (KS-U15K) for connecting it to this unit.

Before operating your CD automatic changer:

- Refer also to the Instructions supplied with your CD changer.
- If no discs are in the magazine of the CD changer or the discs are inserted upside down, "NO CD" or "NO DISC" will appear on the display. If this happens, remove the magazine and set the discs correctly.
- If "RESET 1 - RESET 8" appears on the display, something is wrong with the connection between this unit and the CD changer. If this happens, check the connection, connect the connecting cord(s) firmly if necessary, then press the reset button of the CD changer.

Playing CDs

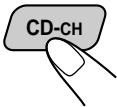
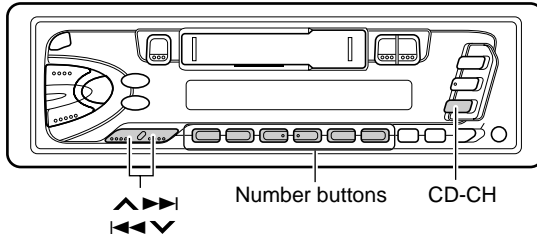

Select the CD automatic changer.

Playback starts from the first track of the first disc.
All tracks of all discs are played back.

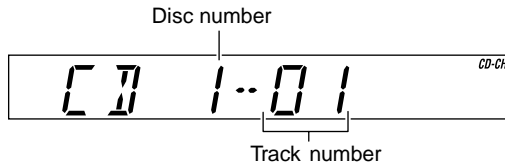

Note on One-Touch Operation:

When you press CD-CH, the power automatically comes on. You do not have to press to turn on the power.



To fast-forward or reverse the track

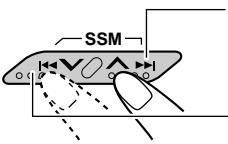

Press and hold **▶▶▶**, while playing a CD, to fast-forward the track.

Press and hold **◀◀◀**, while playing a CD, to reverse the track.

To go to the next tracks or the previous tracks

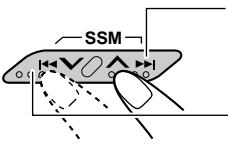

Press **▶▶▶** briefly, while playing a CD, to go ahead to the beginning of the next track. Each time you press the button consecutively, the beginning of the next tracks is located and played back.

Press **◀◀◀** briefly, while playing a CD, to go back to the beginning of the current track. Each time you press the button consecutively, the beginning of the previous tracks is located and played back.

To go to a particular disc directly

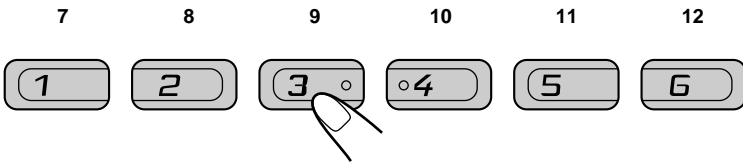

Press the number button corresponding to the disc number to start its playback (while the CD changer is playing).

- To select a disc number from 1 – 6:
Press 1 (7) – 6 (12) briefly.
- To select a disc number from 7 – 12:
Press and hold 1 (7) – 6 (12) for more than 1 second.

Ex. When disc number 3 is selected

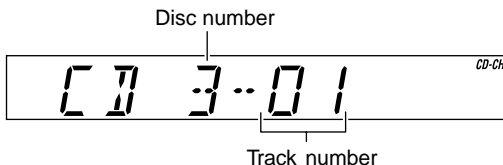



Selecting CD playback modes

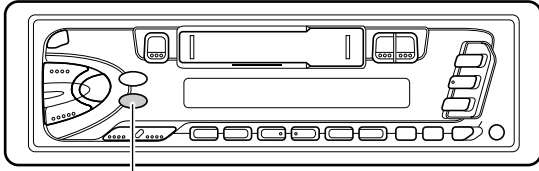

MO/RND

To play back tracks at random (Random Play)



Each time you press MO/RND (mono/random) while playing a CD, CD random play mode changes as follows:

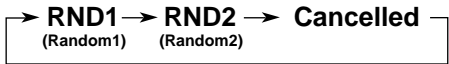

Mode	RND Indicator	Plays at random
RND1	Lights	All tracks of the current disc, then the tracks of the next disc, and so on.
RND2	Flashes	All tracks of all discs inserted in the magazine.

To extend the lifetime of the unit

This unit requires very little attention, but you will be able to extend the life of the unit if you follow the instructions below.

To clean the heads

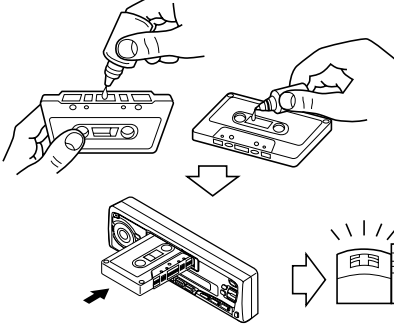

- Clean the heads after every 10 hours of use using a wet-type head cleaning tape (available at an audio store).
When the head becomes dirty, you may realize the following symptoms:
 - Sound quality is reduced.
 - Sound level decreases.
 - Sound drops out.
- Do not play dirty or dusty tapes.
- Do not touch the highly-polished head with any metallic or magnetic tools.

To keep the tape clean

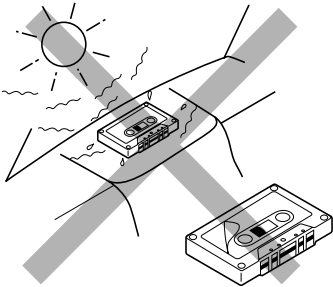

- Always store the tapes to their storage cases after use.
- Do not store tapes in the following places:
 - Subject to direct sunlight
 - With high humidity
 - At extremely hot temperatures

CAUTIONS:

- *Do not play the tapes with peeling labels; otherwise, they can damage the unit.*
- *Tighten tapes to remove slack since loose tape may become entangled with the mechanism.*
- *Do not leave a cassette in the cassette compartment after use, as the tape may become slack.*



TROUBLESHOOTING

ENGLISH

What appears to be trouble is not always serious. Check the following points before calling a service center.

Symptoms	Causes	Remedies
• A cassette tape cannot be inserted.	You have tried to insert a cassette in the wrong way.	Insert the cassette with the exposed tape facing right.
• Cassette tapes become hot.	This is not a malfunction.	_____
• Tape sound is at very low level and sound quality is degraded.	The tape head is dirty.	Clean it with a head cleaning tape.
• Sound is sometimes interrupted.	Connections are not good.	Check the cords and connections.
• Sound cannot be heard from the speakers.	The volume control is turned to the minimum level.	Adjust it to the optimum level.
	Connections are incorrect.	Check the cords and connections.
• SSM (Strong-station Sequential Memory) automatic preset does not work.	Signals are too weak.	Store stations manually.
• Static noise while listening to the radio.	The antenna is not connected firmly.	Connect the antenna firmly.
• “NO CD” or “NO DISC” appears on the display.	No CD is in the magazine.	Insert CDs into the magazine.
	CDs are inserted incorrectly.	Insert them correctly.
• “RESET 8” appears on the display.	This unit is not connected to a CD changer correctly.	Connect this unit and the CD changer correctly and press the reset button of the CD changer.
• “RESET 1 – RESET 7” appears on the display.	_____	Press the reset button of the CD changer.

AUDIO AMPLIFIER SECTION

Maximum Power Output:

Front: 40 W per channel

Rear: 40 W per channel

Continuous Power Output (RMS):

Front: 16 W per channel into 4 Ω ,
40 Hz to 20 000 Hz at no more
than 0.8% total harmonic
distortion.

Rear: 16 W per channel into 4 Ω ,
40 Hz to 20 000 Hz at no more
than 0.8% total harmonic
distortion.

Load Impedance: 4 Ω (4 Ω to 8 Ω allowance)

Tone Control Range

Bass: ± 10 dB at 100 Hz

Treble: ± 10 dB at 10 kHz

Frequency Response: 40 Hz to 20 000 Hz

Signal-to-Noise Ratio: 70 dB

Line-Out Level/Impedance: 2.0 V/20 k Ω load

TUNER SECTION

Frequency Range

FM: 87.5 MHz to 108.0 MHz

AM: (MW) 522 kHz to 1 620 kHz

(LW) 144 kHz to 279 kHz

[FM Tuner]

Usable Sensitivity: 11.3 dBf (1.0 μ V/75 Ω)

50 dB Quieting Sensitivity:

16.3 dBf (1.8 μ V/75 Ω)

Alternate Channel Selectivity (400 kHz):

65 dB

Frequency Response: 40 Hz to 15 000 Hz

Stereo Separation: 30 dB

Capture Ratio: 1.5 dB

[MW Tuner]

Sensitivity: 20 μ V

Selectivity: 35 dB

[LW Tuner]

Sensitivity: 50 μ V

CASSETTE DECK SECTION

Wow & Flutter: 0.15% (WRMS)

Fast-Wind Time: 190 sec. (C-60)

Frequency Response:

50 Hz to 14 000 Hz

Signal-to-Noise Ratio: 52 dB

Stereo Separation: 40 dB

GENERAL

Power Requirement

Operating Voltage: DC 14.4 V (11 V to 16 V
allowance)

Grounding System: Negative ground

Allowable Operating Temperature:

0 $^{\circ}$ C to +40 $^{\circ}$ C

Dimensions (W \times H \times D)

Installation Size: 182 mm \times 52 mm \times 150 mm

Panel Size: 188 mm \times 58 mm \times 14 mm

Mass: 1.3 kg (excluding accessories)

*Design and specifications subject to change
without notice.*



JVC
VICTOR COMPANY OF JAPAN, LIMITED

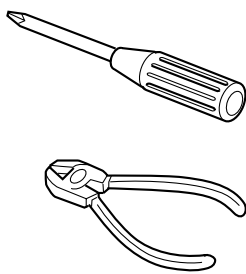

ENGLISH

- This unit is designed to operate on 12 volts DC, NEGATIVE ground electrical systems.

INSTALLATION (IN-DASH MOUNTING)

- The following illustration shows a typical installation. However, you should make adjustments corresponding to your specific car. If you have any questions or require information regarding installation kits, consult your JVC IN-CAR ENTERTAINMENT dealer or a company supplying kits.

- 1 Before mounting:** Press (Control Panel Release button) to detach the control panel.
- Remove the trim plate.
- Remove the sleeve after disengaging the sleeve locks.
 - Stand the unit.

Note: When you stand the unit, be careful not to damage the fuse on the rear.
 - Insert the 2 handles between the unit and the sleeve, as illustrated, to disengage the sleeve locks.
 - Remove the sleeve.

Note: Be sure to keep the handles for future use after installing the unit.
- Install the sleeve into the dashboard.

* After the sleeve is correctly installed into the dashboard, bend the appropriate tabs to hold the sleeve firmly in place, as illustrated.
- Fix the mounting bolt to the rear of the unit's body and place the rubber cushion over the end of the bolt.
- Do the required electrical connections.
- Slide the unit into the sleeve until it is locked.
- Attach the trim plate so that the projection on the trim plate is fixed to the left side of the unit.
- Attach the control panel.

DEUTSCH

- Dieses Gerät ist nur für einen Betrieb in elektrischen Anlagen mit 12 V Gleichstrom und (-) Erdung ausgelegt.

EINBAU (IM ARMATURENBRETT)

- Die folgende Abbildung zeigt einen typischen Einbau. Dennoch müssen Sie entsprechend Ihrem jeweiligen Auto Anpassungen vornehmen. Bei irgendwelchen Fragen oder wenn Sie Informationen hinsichtlich des Einbausatzes brauchen, wenden Sie sich an ihren JVC Autoradiohändler oder ein Unternehmen das diese Einbausätze vertreibt.

- 1 Vor dem Einbau:** (Schalttafel-Freigabetaste) zum Lösen der Schalttafel drücken.
- Den Frontrahmen herausnehmen.
- Die Halterung nach dem Entriegeln der Halterungssperren abnehmen.
 - Das Gerät aufstellen.

Hinweis: Beim Aufstellen des Geräts darauf achten, daß die Sicherung auf der Rückseite nicht beschädigt wird.
 - Die beiden Griffe zwischen dem Gerät und der Halterung wie abgebildet einstecken und die Halterungssperren entriegeln.
 - Die Halterung entfernen.

Hinweis: Sicherstellen, daß die Griffe für künftigen Gebrauch nach dem Einbau des Geräts aufbewahrt werden.
- Die Halterung im Armaturenbrett einbauen.

* Nach dem korrekten Einbau der Halterung im Armaturenbrett, die entsprechenden Riegel umknicken, um die Halterung an ihrem Platz zu sichern, siehe Abbildung.
- Die Befestigungsschraube an der Rückseite des Gerätekörpers befestigen und das Ende der Schraube mit einem Gummipuffer abdecken.
- Nehmen Sie die erforderlichen elektrischen Anschlüsse vor.
- Das Gerät in die Halterung schieben, bis es einrastet.
- Befestigen Sie die Frontrahmen in der Form, daß der Fortsatz der Frontrahmen auf der linken Seite des Geräts befestigt wird.
- Die Schalttafel anbringen.

FRANÇAIS

- Cet appareil est conçu pour fonctionner sur des sources de courant continu de 12 volts à masse NEGATIVE.

INSTALLATION (MONTAGE DANS LE TABLEAU DE BORD)

- L'illustration suivante est un exemple d'installation typique. Cependant, vous devez faire les ajustements correspondant à votre voiture particulière. Si vous avez des questions ou avez besoin d'information sur des kits d'installation, consulter votre revendeur d'autoradios JVC ou une compagnie d'approvisionnement.

- 1 Avant le montage:** Appuyer sur (touche de libération du panneau de commande) pour détacher le panneau de commande.
- Retirer la plaque d'assemblage.
- Libérer les verrous du manchon et retirer le manchon.
 - Poser l'appareil à la verticale.

Remarque: Lorsque vous mettez l'appareil à la verticale, faire attention de ne pas endommager le fusible situé sur le fond.
 - Insérer les 2 poignées entre l'appareil et le manchon comme indiqué pour désengager les verrous de manchon.
 - Retirer le manchon.

Remarque: S'assurer de garder les poignées pour une utilisation ultérieure, après l'installation de l'appareil.
- Installer le manchon dans le tableau de bord.

* Après installation correcte du manchon dans le tableau de bord, plier les bonnes pattes pour maintenir fermement le manchon en place, comme montré.
- Monter le boulon de montage sur l'arrière du corps de l'appareil puis passer l'amortisseur en caoutchouc sur l'extrémité du boulon.
- Réalisez les connexions électriques.
- Faire glisser l'appareil dans le manchon jusqu'à ce qu'il soit verrouillé.
- Attachez la plaque d'assemblage de façon que la projection de la plaque soit fixée sur le côté gauche de l'appareil.
- Remonter le panneau de commande.

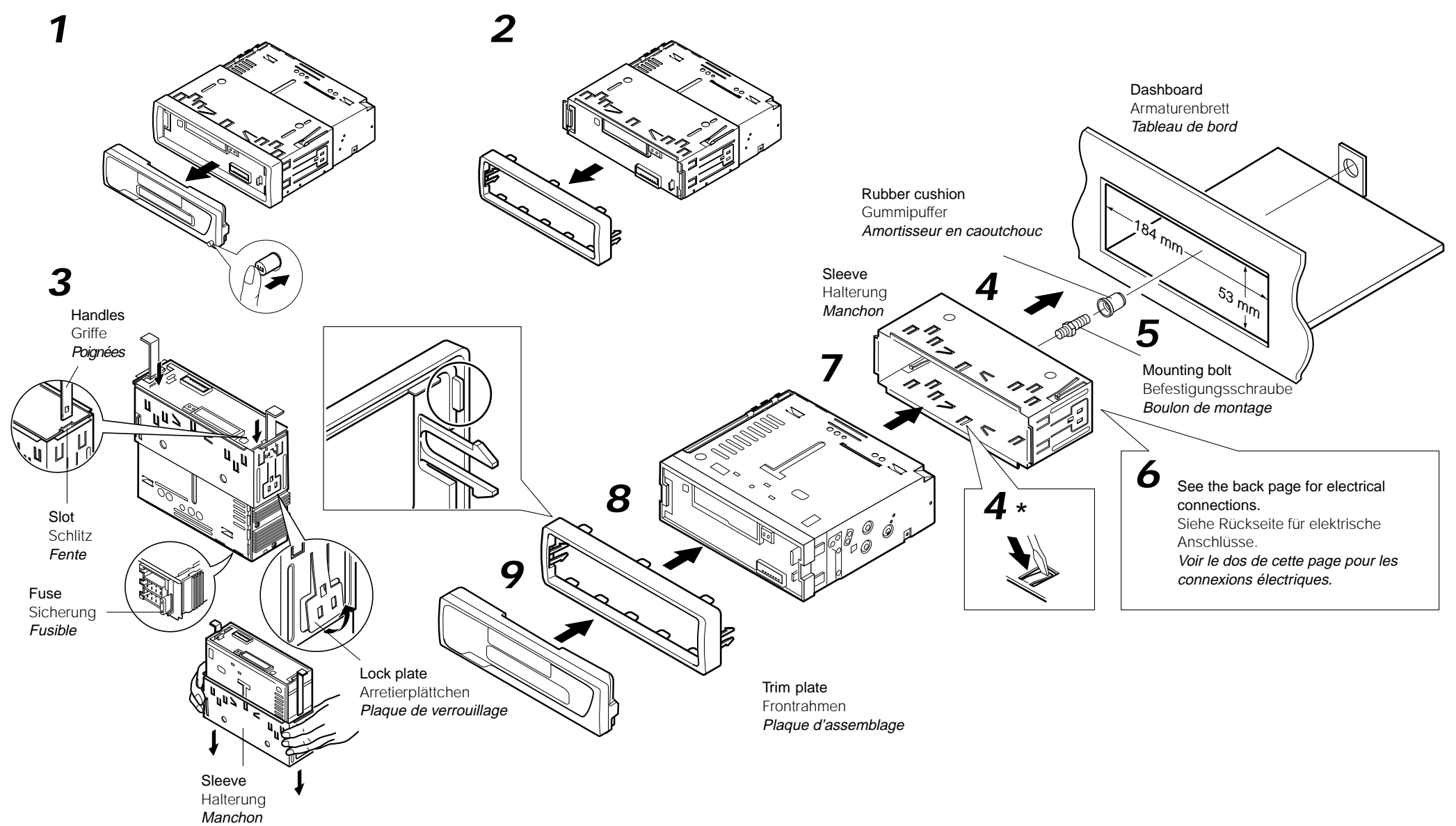

- When using the optional stay
- Beim Verwenden der Anker-Option
- Lors de l'utilisation du hauban en option

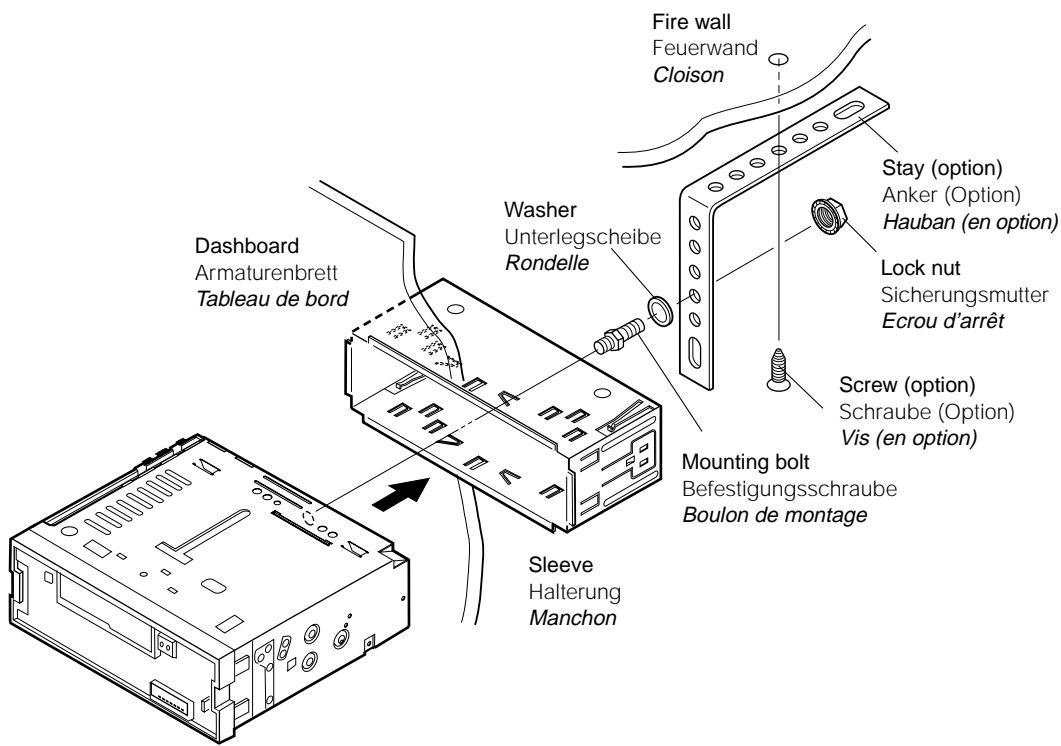

- When installing the unit without using the sleeve
- Beim Einbau des Geräts ohne Halterung
- Lors de l'installation de l'appareil sans utiliser de manchon

In a Toyota for example, first remove the car radio and install the unit in its place.
Zum Beispiel in einem Toyota zuerst das Autoradio ausbauen und dann das Gerät an seinem Platz einbauen.
Par exemple dans une Toyota, retirer d'abord l'autoradio et installer l'appareil à la place.

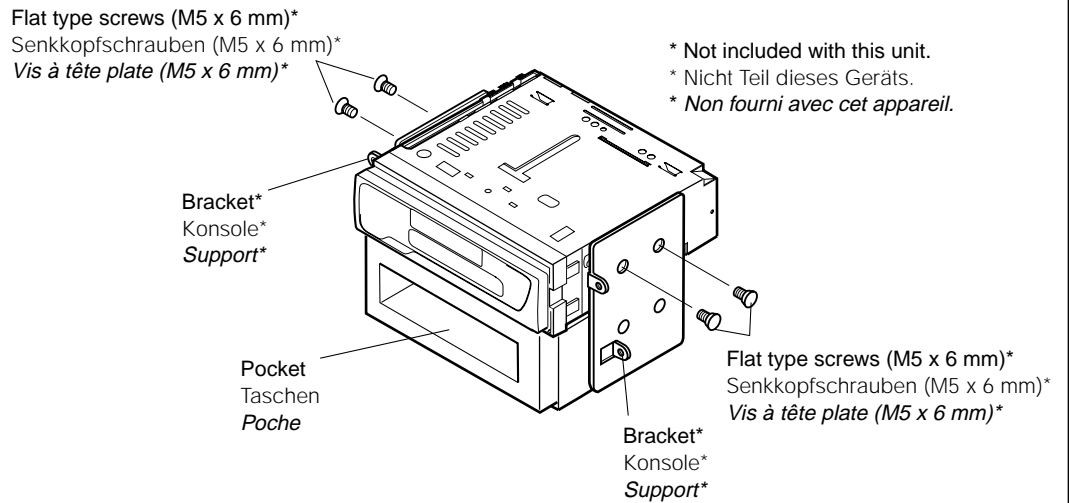

Nota: When installing the unit on the mounting bracket, make sure to use the 6 mm-long screws. If longer screws are used, they could damage the unit.

Hinweis: Beim Anbringen des Gerät an der Konsole sicherstellen, daß 6 mm lange Schrauben verwendet werden. Werden längere Schrauben verwendet, können sie das Gerät beschädigen.

Remarque: Lors de l'installation de l'appareil sur le support de montage, s'assurer d'utiliser des vis d'une longueur de 6 mm. Si des vis plus longues sont utilisées, elles peuvent endommager l'appareil.

Removing the unit

- Before removing the unit, release the rear section.

- 1 Remove the control panel.
- 2 Remove the trim plate.
- 3 Insert the 2 handles into the slots, as shown. Then, while gently pulling the handles away from each other, slide out the unit. (Be sure to keep the handles after installing it.)

Ausbau des Geräts

- Vor dem Ausbau des Geräts den hinteren Teil freigeben.

- 1 Die Schalltafel abnehmen.
- 2 Den Frontrahmen abnehmen.
- 3 Die 2 Griffe in die Schlitz wie gezeigt stecken. Dann die Griffe behutsam auseinander ziehen und das Gerät herausziehen. (Die Griffe nach dem Einbau auf jeden Fall aufbewahren.)

Retrait de l'appareil

- Avant de retirer l'appareil, libérer la section arrière.

- 1 Retirer le panneau de commande.
- 2 Retirer la plaque d'assemblage.
- 3 Introduire les deux poignées dans les fentes, comme montré. Puis, tout en tirant doucement les poignées écartées, faire glisser l'appareil pour le sortir. (S'assurer de conserver les poignées après l'installation de l'appareil.)

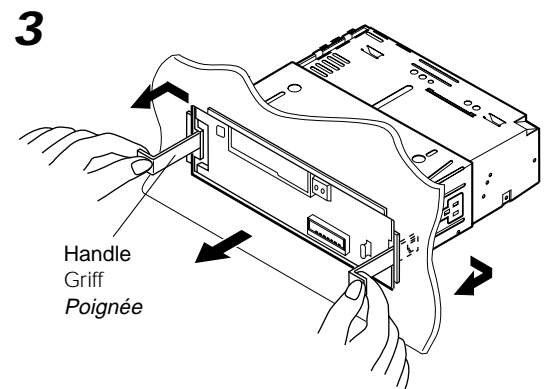
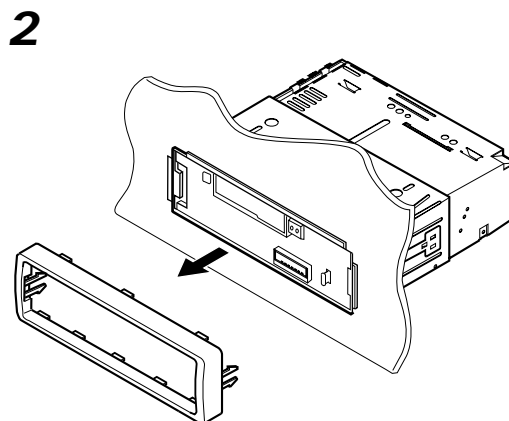
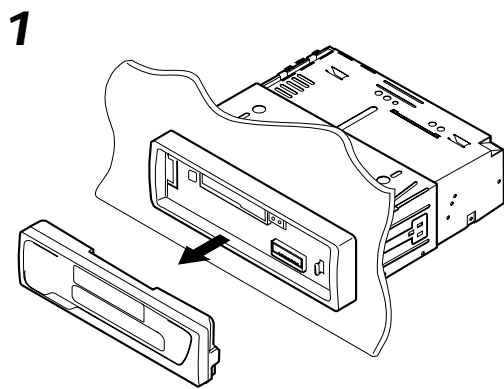

Parts list for installation and connection

The following parts are provided with this unit.
After checking them, please set them correctly.

Hard case
Etui
Etui de transport

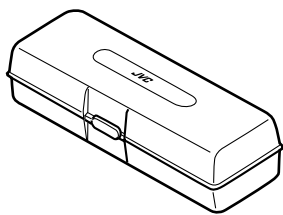

Trim plate
Frontrahmen
Plaque d'assemblage

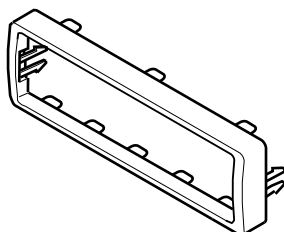

Sleeve
Halterung
Manchon

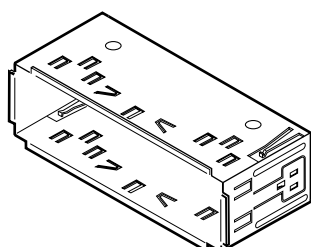

Teileliste für den Einbau und Anschluß

Die folgenden Teile werden zusammen mit diesem Gerät geliefert.
Nach ihrer Überprüfung, die Teile richtig einsetzen.

Power cord
Spannungsversorgungskabel
Cordon d'alimentation

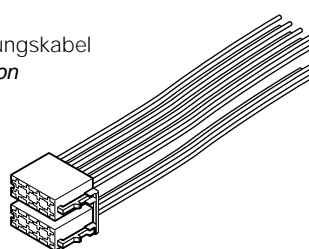

Handles
Griffe
Poignées

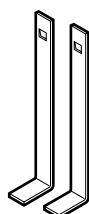

Rubber cushion
Gummipuffer
Amortisseur en caoutchouc



Liste des pièces pour l'installation et raccordement

Les pièces suivantes sont fournies avec cet appareil.
Après vérification, veuillez les placer correctement.

Lock nut (M5)
Sicherungsmutter (M5)
Ecrou d'arrêt (M5)



Mounting bolt (M5 x 20 mm)
Befestigungsschrauben (M5 x 20 mm)
Boulon de montage (M5 x 20 mm)



Washer (ø5)
Unterlegscheibe (ø5)
Rondelle (ø5)



ELECTRICAL CONNECTIONS

ELEKTRISCHE ANSCHLÜSSE

RACCORDEMENTS ELECTRIQUES

To prevent short circuits, we recommend that you disconnect the battery's negative terminal and make all electrical connections before installing the unit. If you are not sure how to install this unit correctly, have it installed by a qualified technician.

Note:
This unit is designed to operate on **12 volts DC, NEGATIVE ground electrical systems**. If your vehicle does not have this system, a voltage inverter is required, which can be purchased at JVC IN-CAR ENTERTAINMENT dealers.

- Replace the fuse with one of the specified rating. If the fuse blows frequently, consult your JVC IN-CAR ENTERTAINMENT dealer.
- If noise is a problem...
This unit incorporates a noise filter in the power circuit. However, with some vehicles, clicking or other unwanted noise may occur. If this happens, connect the unit's **rear ground terminal** (See connection diagram below.) to the car's chassis using shorter and thicker cords, such as copper braiding or gauge wire. If noise still persists, consult your JVC IN-CAR ENTERTAINMENT dealer.
- Maximum input of the speakers should be more than 40 watts at the rear and 40 watts at the front, with an impedance of **4 to 8 ohms**.
- **Be sure to ground this unit to the car's chassis.**
- The heat sink becomes very hot after use. Be careful not to touch it when removing this unit.

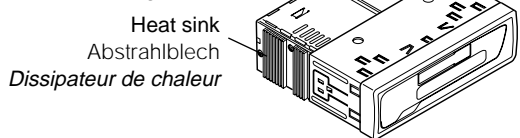

Zur Vermeidung von Kurzschlüssen empfehlen wir, daß Sie den negativen Batterieanschluß abtrennen und alle elektrischen Anschlüsse herstellen, bevor das Gerät eingebaut wird. Sind Sie sich über den richtigen Einbau des Geräts nicht sicher, lassen Sie es von einem qualifizierten Techniker einbauen.

Hinweis:
Dieses Gerät ist für den Betrieb in **elektrischen Anlagen mit 12 V Gleichstrom und (-) Erdung** ausgelegt. Verfügt Ihr Fahrzeug nicht über diese Anlage, ist ein Spannungsinverter erforderlich, der bei JVC Autoradiohändler erworben werden kann.

- Die Sicherung mit einer der entsprechenden Nennleistung ersetzen. Brennt die Sicherung häufig durch, wenden Sie sich an ihren JVC Autoradiohändler.
- Sind Störgeräusche ein Problem...
Dieses Gerät enthält ein Störfilter im Stromkreis. Bei manchen Fahrzeugen kann jedoch ein Klicken oder andere unerwünschte Störgeräusche auftreten. Sollte das der Fall sein, die **hintere Erdungsanschlusssklemme** (siehe Schaltplan unten) des Geräts am Fahrwerk des Fahrzeugs anschließen, dabei kürzere und dickere Kabel wie beispielsweise Kupfergeflecht draht oder Stahldraht verwenden. Bleibt Störgeräusch bestehen, wenden Sie sich an Ihren JVC Autoradiohändler.
- Maximale Eingangsleistung der Lautsprecher muß höher als 40 W hinten und 40 W vorne sein, mit einer Impedanz von **4 bis 8 Ohm**.
- **Sicherstellen, daß das Gerät am Fahrwerk geerdet wird.**
- Das Abstrahlblech wird nach dem Gebrauch sehr heiß. Beim Ausbau des Geräts darauf achten, das Abstrahlblech nicht zu berühren.

Pour éviter tout court-circuit, nous vous recommandons de débrancher la borne négative de la batterie et d'effectuer tous les raccordements électriques avant d'installer l'appareil. Si l'on n'est pas sûr de pouvoir installer correctement cet appareil, le faire installer par un technicien qualifié.

Remarque:
Cet appareil est conçu pour fonctionner sur des sources de courant continu de **12 volts à masse NEGATIVE**. Si votre véhicule n'offre pas ce type d'alimentation, il vous faut un convertisseur de tension, que vous pouvez acheter chez un revendeur d'autoradios JVC.

- Remplacer le fusible par un de la valeur précisée. Si le fusible saute souvent, consulter votre revendeur d'autoradios JVC.
- Si le bruit est un problème...
Cet appareil incorpore un filtre de bruit dans le circuit d'alimentation. Cependant, avec certains véhicules, quelques claquements ou autres bruits non désirés risquent de se produire. Si cela arrive, raccorder la borne de masse arrière de l'appareil au châssis de la voiture (voir le schéma de raccordement ci-dessous) en utilisant des cordons les plus gros et les plus courts possibles telle qu'une barre de cuivre ou une tresse. Si le bruit persiste, consulter votre revendeur d'autoradios JVC.
- La puissance admissible des haut-parleurs doit être supérieure à 40 watts à l'arrière et à 40 watts l'avant, avec une impédance de **4 à 8 ohms**.
- **S'assurer de raccorder la mise à la masse de cet appareil au châssis de la voiture.**
- Le radiateur devient très chaud après usage. Faire attention de ne pas le toucher en retirant cet appareil.

A Typical Connections / Typische Anschlüsse / Raccordements typiques

Before connecting: Check the wiring in the vehicle carefully. Incorrect connection may cause serious damage to this unit.

- 1 Connect the colored leads of the power cord to the car battery, speakers and power aerial (if any) in the following sequence.
 - ① Black: ground
 - ② Yellow: to car battery (constant 12V)
 - ③ Red: to an accessory terminal
 - ④ Blue with white stripe: to power aerial (200mA max.)
 - ⑤ Brown: to cellular phone system (For details, refer to the instructions of the cellular phone.)
 - ⑥ Others: to speakers
- 2 Connect the antenna cord.
- 3 Finally connect the wiring harness to the unit.

Note: If your vehicle does not have any accessory terminal, move the fuse from the fuse position 1 (initial position) to fuse position 2, and connect the red lead (A7) to the positive (+) battery terminal.

- The yellow lead (A4) is not used in this case.

Vor dem Anschließen: Die Verdrahtung im Fahrzeug sorgfältig überprüfen. Falsche Anschlüsse können ernsthafte Schäden am Gerät hervorrufen.

- 1 Die farbigen Leitungen des Spannungsversorgungskabels an der Autobatterie, den Lautsprechern und dem Motorantenne (sofern vorhanden) in folgender Reihenfolge anschließen.
 - ① Schwarz: Erdung
 - ② Gelb: an Autobatterie (konstant 12 V)
 - ③ Rot: an Zubehörananschlußklemme
 - ④ Blau mit weißem Streifen: an Motorantenne (200mA maximale)
 - ⑤ Braun: an Mobiltelefon (Weitere Informationen entnehmen Sie bitte der Bedienungsanleitung des Mobiltelefons.)
 - ⑥ Andere: an Lautsprecher
- 2 Das Antennenkabel anschließen.
- 3 Die Kabelbäume am Gerät anschließen.

Hinweis: Verfügt Ihr Fahrzeug nicht über eine Zubehörananschlußklemme, die Sicherung von der 1. Sicherungsposition (Erstposition) in die 2. Sicherungsposition versetzen, die rote Leitung (A7) an der (+) Batterieanschlußklemme anschließen.

- Die gelbe Leitung (A4) wird in diesem Fall nicht verwendet.

Avant de commencer la connexion: vérifiez attentivement le câblage du véhicule. Une connexion incorrecte peut endommager sérieusement l'appareil.

- 1 Connectez les fils de couleur du cordon d'alimentation à la batterie de la voiture, aux enceintes et à l'antenne automatique (s'il y en a une) dans l'ordre suivant.
 - ① Noir: à la masse
 - ② Jaune: à la batterie de la voiture (12V constant)
 - ③ Rouge: à la prise accessoire
 - ④ Bleu à bandes blanches: à l'antenne automatique (200mA maximum)
 - ⑤ Marron: à un système de téléphone cellulaire (Pour les détails, se référer aux instructions du téléphone cellulaire.)
 - ⑥ Autres: aux enceintes
- 2 Connectez le cordon d'antenne.
- 3 Finalement, connectez le faisceau de fils à l'appareil.

Remarque: Si votre véhicule ne possède pas de borne accessoire, déplacez le fusible de la position de fusible 1 (position originale) à la position de fusible 2 et connectez le fil rouge (A7) à la borne positive (+) de la batterie.

- Le fil jaune (A4) n'est pas utilisé dans ce cas.

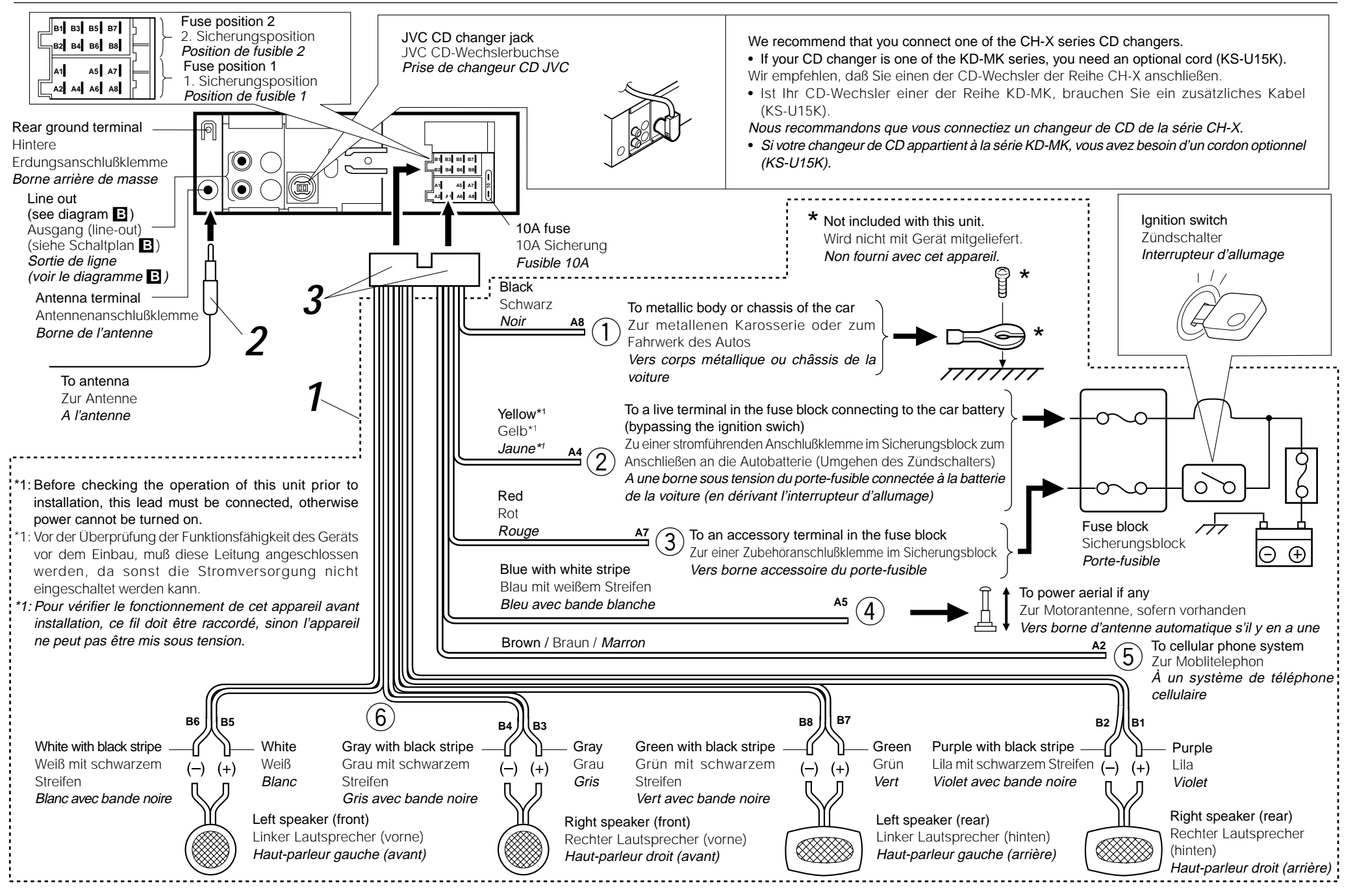

PRECAUTIONS on power supply and speaker connections:

- **DO NOT** connect the speaker leads of the power cord to the car battery; otherwise, the unit will be seriously damaged.
- Connect the black lead (ground), yellow lead (to car battery, constant 12V), and red lead (to an accessory terminal) correctly.
- **BEFORE** connecting the speaker leads of the power cord to the speakers, check the speaker wiring in your car.
 - **If the speaker wiring in your car is as illustrated in Fig. 1 and Fig. 2 below, DO NOT** connect the unit using that original speaker wiring. If you do, the unit will be seriously damaged. Redo the speaker wiring so that you can connect the unit to the speakers as illustrated in Fig. 3.
 - **If the speaker wiring in your car is as illustrated in Fig. 3,** you can connect the unit using the original speaker wiring in your car.
 - If you are not sure of the speaker wiring of your car, consult your car dealer.

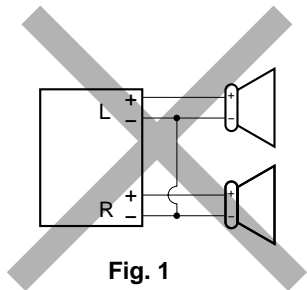

Fig. 1

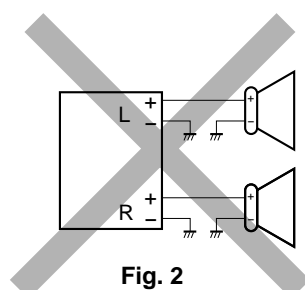

Fig. 2

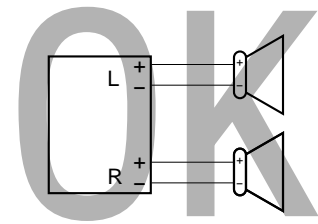

Fig. 3

VORSICHTSMASSREGELN beim Anschließen der Stromversorgung und Lautsprecher:

- **Die Lautsprecherleitungen des Netzkabels NICHT an der Autobatterie anschließen, da sonst das Gerät schwer beschädigt wird.**
- Die schwarze Leitung (Erdung), die gelbe Leitung (zur Autobatterie, konstant 12 V) und die rote Leitung (zur Zubehöranschlusßklemme) richtig anschließen.
- **VOR** dem Anschließen der Lautsprecherleitungen des Spannungsversorgungskabels an die Lautsprecher, die Lautsprecherverdrahtung in Ihrem Auto überprüfen.
 - **Ist die Lautsprecherverdrahtung wie unten in "Fig. 1" und "Fig. 2" abgebildet,** das Gerät NICHT mit der Originalverdrahtung der Lautsprecher anschließen, da sonst das Gerät schwer beschädigt wird. Die Lautsprecherverdrahtung erneuern, so daß Sie das Gerät an den Lautsprechern wie in "Fig. 3" abgebildet anschließen können.
 - **Ist die Lautsprecherverdrahtung in Ihrem Auto wie in "Fig. 3" abgebildet,** können Sie das Gerät mit der Originalverdrahtung der Lautsprecher in Ihrem Auto anschließen.
 - Sind Sie sich über die Lautsprecherverdrahtung in Ihrem Auto nicht sicher, wenden Sie sich an Ihren Autohändler.

PRECAUTIONS sur l'alimentation et la connexion des enceintes:

- **NE CONNECTEZ PAS** les fils d'enceintes du cordon d'alimentation à la batterie; sinon, l'appareil serait sérieusement endommagé.
- Connectez correctement le fil noir (à la masse), le fil jaune (à la batterie de la voiture, 12V constant) et le fil rouge (à la prise accessoire).
- **AVANT** de connecter les fils d'enceintes du cordon d'alimentation aux enceintes, vérifiez le câblage des enceintes de votre voiture.
 - **Si le câblage des enceintes de votre voiture est réalisé comme montré sur la Fig. 1 ou Fig. 2 ci-dessous, NE CONNECTEZ PAS** l'appareil en utilisant ce câblage original d'enceintes. Si vous le faites, l'appareil sera sérieusement endommagé. Recommencez le câblage des enceintes de façon que vous puissiez connecter l'appareil aux enceintes comme montré sur la Fig. 3.
 - **Si le câblage des enceintes de votre voiture est comme montré sur la Fig. 3,** vous pouvez connecter l'appareil en utilisant ce câblage original d'enceintes pour votre voiture.
 - Si vous n'êtes pas sûrs du câblage d'enceintes de votre voiture, consultez le concessionnaire de votre voiture.

Connecting the leads / Anschließen der Leitungen / Raccordement des fils

Twist the core wires when connecting.
Die Kerndrähte beim Anschließen verdrehen.
Torsader les âmes des fils en les raccordant.

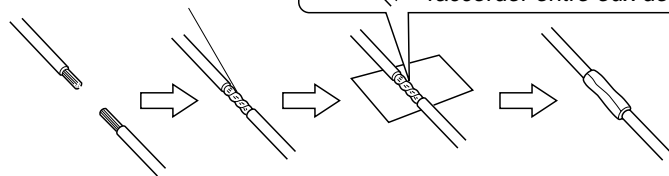

Solder the core wires to connect them securely.
Die Kerndrähte anlöten, um sie fest anzuschließen.
Souder les âmes des fils pour les raccorder entre eux de façon sûre.

CAUTION / VORSICHT/ PRECAUTION:

- To prevent short-circuit, cover the terminals of the UNUSED leads with insulating tape.
- Zur Vermeidung eines Kurzschlusses die Anschlußklemmen der NICHT VERWENDETEN Leitungen mit Isolierklebeband umwickeln.
- Pour éviter les court-circuits, couvrir les bornes des fils qui ne sont PAS utilisés avec de la bande isolante

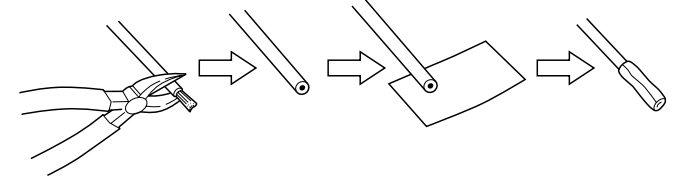

Connections Adding Other Equipment / Anschlüsse zum Hinzufügen von anderer Ausrüstung / Raccordement pour ajouter d'autres appareils

Since this unit has line-out terminals, an amplifier and other equipment can be used to upgrade your car stereo system.

- Connect the remote lead (blue with white stripe) to the remote lead of the other equipment so that it can be controlled through this unit.
- For amplifier only: Connect this unit's line-out terminals to the amplifier's line-in terminals.

Da dieses Gerät Anschlußklemmen am Ausgang (line-out) hat, können ein Verstärker und andere Ausrüstung zur Aufwertung Ihrer Autostereoanlage verwendet werden.

- Schließen Sie das Fernbedienungskabel (blau mit weißem Streifen) an das Fernbedienungskabel des anderen Geräts an, so daß es über dieses Gerät gesteuert werden kann.
- Nur für den Verstärker: Die Anschlußklemmen am Ausgang (line-out) dieses Gerät an den Anschlußklemmen des Ausgangs (line-out) des Verstärkers anschließen.

Comme cet appareil a des bornes de sortie de ligne, un amplificateur et d'autres appareils peuvent être utilisés pour améliorer votre chaîne stéréo automobile.

- Connectez le fil de commande à distance (bleu avec bande blanche) au fil de commande à distance de l'autre appareil de façon qu'il puisse être commandé via cet appareil.
- Pour l'amplificateur seulement: Raccorder les bornes de sortie ligne de cet appareil aux bornes d'entrée ligne de l'amplificateur.

Amplifier / Verstärker / Amplificateur

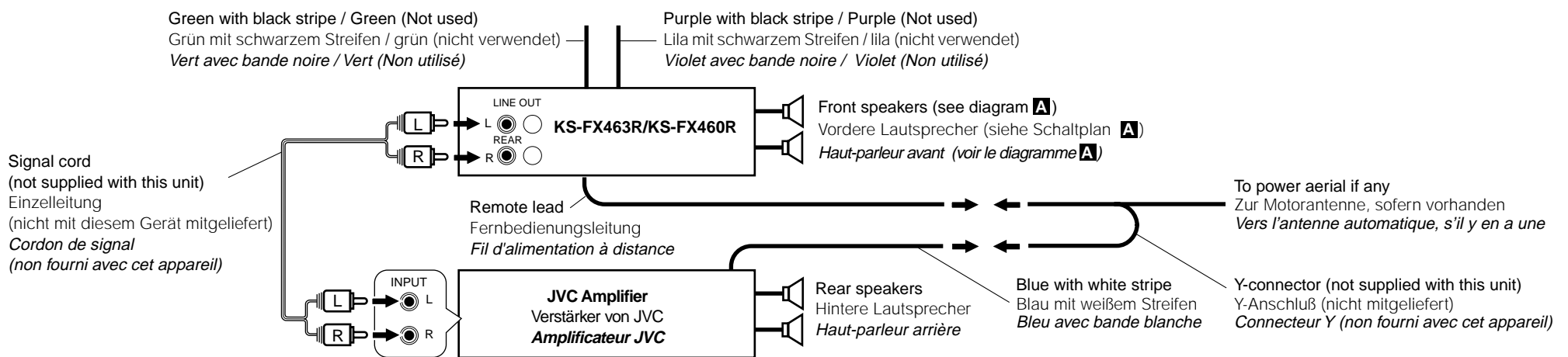

TROUBLESHOOTING

- **The fuse blows.**
 - * Are the red and black leads connected correctly?
- **Power cannot be turned on.**
 - * Is the yellow lead connected?
- **No sound from the speakers.**
 - * Is the speaker output lead short-circuited?
- **Sound is distorted.**
 - * Is the speaker output lead grounded?
 - * Are the "-" terminals of L and R speakers grounded in common?
- **Unit becomes hot.**
 - * Is the speaker output lead grounded?
 - * Are the "-" terminals of L and R speakers grounded in common?

FEHLERSUCHE

- **Die Sicherung brennt durch.**
 - * Sind die roten und schwarzen Leitungen richtig angeschlossen?
- **Stromversorgung kann nicht eingeschaltet werden.**
 - * Ist die gelbe Leitung angeschlossen?
- **Kein Ton aus den Lautsprechern.**
 - * Ist die Lautsprecherausgangsleitung kurzgeschlossen?
- **Ton verzerrt.**
 - * Ist die Lautsprecherausgangsleitung geerdet?
 - * Sind die (-) Anschlußklemmen der linken und rechten Lautsprecher zusammen geerdet?
- **Gerät wird heiß.**
 - * Ist die Lautsprecherausgangsleitung geerdet?
 - * Sind die (-) Anschlußklemmen der linken und rechten Lautsprecher zusammen geerdet?

EN CAS DE DIFFICULTÉS

- **Le fusible saute.**
 - * Les fils rouge et noir sont-ils raccordés correctement?
- **L'appareil ne peut pas être mise sous tension.**
 - * Le fil jaune est-elle raccordée?
- **Pas de son des haut-parleurs.**
 - * Le fil de sortie de haut-parleur est-il court-circuité?
- **Le son est déformé.**
 - * Le fil de sortie de haut-parleur est-il à la masse?
 - * Les bornes "-" des haut-parleurs gauche et droit sont-elles mises ensemble à la masse?
- **L'appareil devient chaud.**
 - * Le fil de sortie de haut-parleur est-il à la masse?
 - * Les bornes "-" des haut-parleurs gauche et droit sont-elles mises ensemble à la masse?